

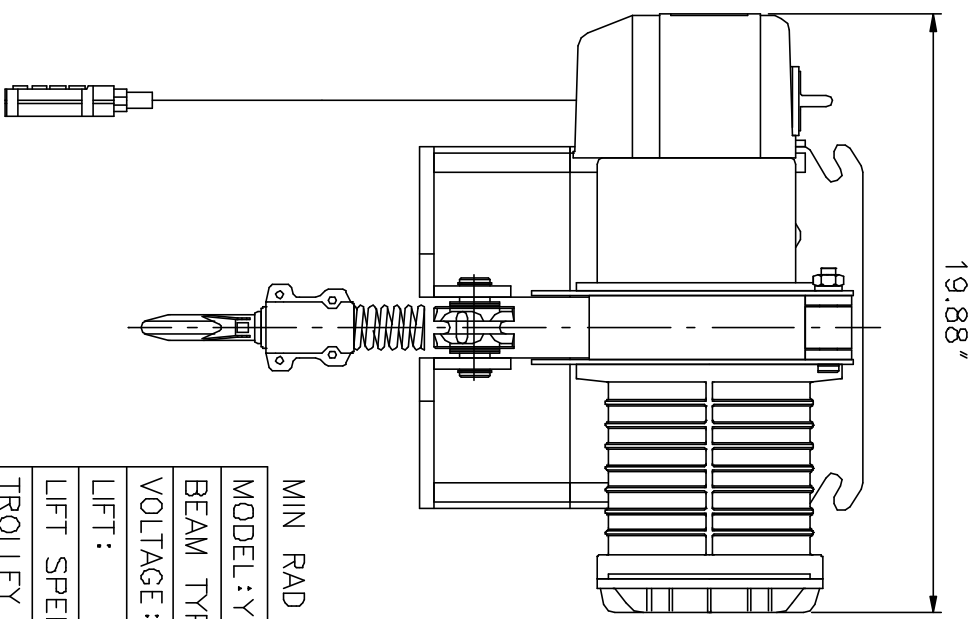

8 7 6 5 4 3 2 1

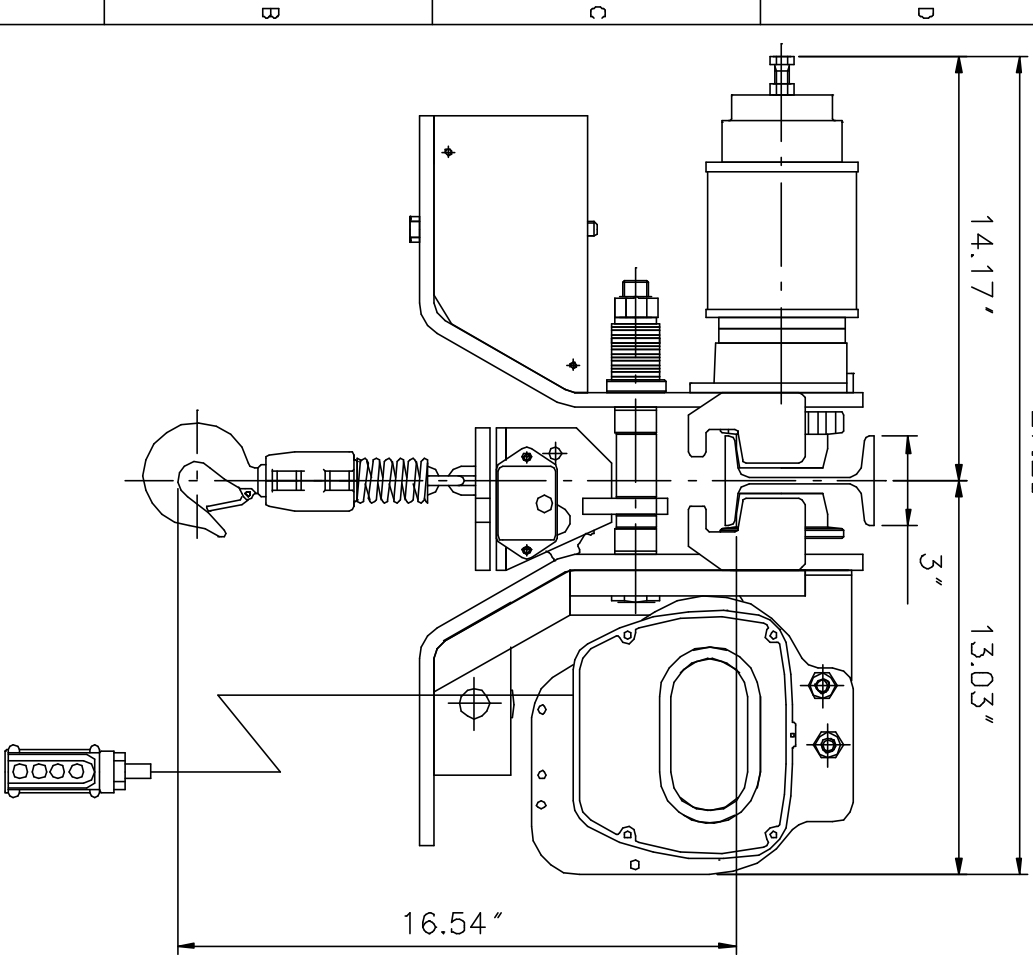

MIN RAD CURVE =
 MODEL: YHT-100
 BEAM TYPE/SIZE: 3'~5'
 VOLTAGE: 3Ø 60HZ 230V/460V-110V
 LIFT:
 LIFT SPEED: 26 ft/min
 TROLLEY SPEED: 79 ft/min
 HOIST CAPACITY: 2200 lbs

件號 ITEM NO.	件 DESCRIPTION	圖號 DWG. NO.	數量 QTY.	材質 MATERIAL	重量 WEIGHT	料號 PARTS NO.
-	-	-	-	-	-	-

位號 SIGN	更改 CORRECTION	更改人 CORRECTOR	日期 DATE	繪圖 DRAWN	設計 DESIGN	審核 CHECKED	比例 SCALE	組料號 ASS. NO.	日期 DATE	林秀芬 LIN SHIU-FUN	林明憲 LIN MING-HAN	日期 DATE
-	-	-	-	-	-	-	1:7	94/12/02	-	-	-	-



誠岱機械廠股份有限公司
 CHENG DAY MACHINERY WORKS CO., LTD.