

Parts Breakdown

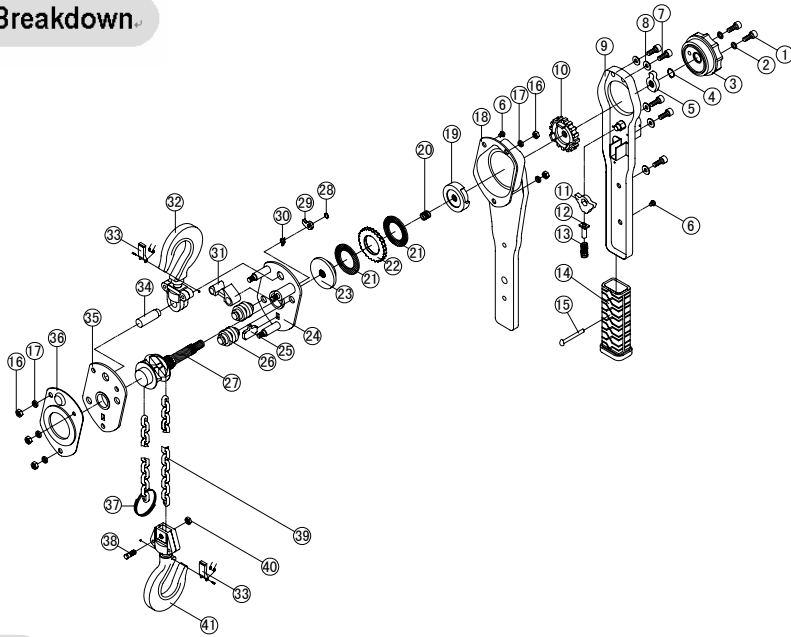

Parts List

NO.	Part NO.	Part Name	Q'ty
1	L1401	Hex. Recess Bolt	2
2	L1441	Spring Washer	2
3	L1001	Hand Wheel	1
4	L1461	C-Ring	1
5	L1002	Stopper	1
6	L1402	Hex. Recess Bolt	2
7	L1403	Hex. Recess Bolt	5
8	L1442	Spring Washer	5
9	L1003	Lever Outside Assembly	1
10	L1004	Feed Gear	1
11	L1005	Feed Ratchet	1
12	L1006	Ratchet Spring Pin	1
13	L1007	Ratchet Spring	1
14	L1008	Rubber Cover	1
15	L1009	rivet	1
16	L1421	Hex. Nut	5
17	L1443	Spring Washer	5
18	L1010	Lever Inside Assembly	1
19	L1011	Feed Gear Cover	1
20	L1012	Free Wheeling Spring	1
21	L1013	Brake Disk	2

NO.	Part NO.	Part Name	Q'ty
22	L1014	Ratchet Wheel	1
23	L1015	Disk Hub	1
24	L1201	Lever Side Plate Assembly	1
25	L1202	Chain Stripper	1
26	L1203	Chain Guide	2
27	L1204	Load Sheave	1
28	L1462	C-Ring	1
29	L1205	Ratchet	1
30	L1206	Ratchet Spring Thimble	1
31	L1207	Position Plate	1
32	L1208	Top Hook Assembly	1
33	L1209	Safety Latch Assembly	2
34	L1210	Top Hook Pin	1
35	L1211	Gear Side Plate Assembly	1
36	L1212	Case	1
37	L1213	Chain Stopper	1
38	L1214	Bolt	1
39	L1901	Load Chain	1
40	L1422	Nylon Lock Nut	1
41	L1215	Bottom Hook Assembly	1



OPERATION MANUAL OF LEVER HOIST

— SAFETY PRECAUTIONS —



DANGER

Lever hoist is designed to pull heavy load. Neglect of following safety precautions might cause the damage to the pulled objects and / or either injury and death disaster.

<p>Never pull over rated load.</p>	<p>Never use deforming or malfunctioning lever hoist.</p>
<p>Never use the load chain to wrap the pulling object and never use when top hook and lower hook do not in line.</p>	<p>Never handle the lever with impact force.</p>
<p>Never use with twisted or kinked load chain.</p>	<p>Never over pulling when load chain reached up or down limit.</p>
<p>Never stand under the pulling objects.</p>	<p>Never use two lever hoist pulling one object.</p>

READ FOLLOWING CAREFULLY BEFORE THE USE OF LEVER HOIST

In using should follow all safety precautions, and always keep the lever hoist in good conditions. Never neglect any single precautions.

OPERATION

- (1). Pull up, move direction indicator position "UP", pull lever up and down.
- (2). Pull down, move direction indicator do position "DOWN", pull lever up and down.

FREE CHAIN

Move direction indicator position "F" in center, and turn the running wheel anti-clockwise at least 90 degree, the load chain can be pull up or down freely by hand.

CAUTION

In free chain application never hook and load.

MAINTENANCE AFTER USING

First should clean dust, water, moisture, thoroughly, and lubricate the load chain, hook, and all revolving parts then keep in dry place.

INSPECTION BEFORE USE

Each time before put lever hoist into use, need to inspect the unit, any deformed of parts need to be replaced.

- (1). Outlooking inspection: Please inspect any deformation happen of followings; load chain, top and bottom hook, bolts, safety latch, chain stopper, lever outside, hook block half and cover, any deform being found replace it.
- (2). Disassembling inspection: Periodically disassemble the unit and check for any deformation or wore out of followings; ratchet, ratchet wheel, brake disk, free wheel spring, gears and load sheave, being found replace it.
- (3). Be sure the two sides of brake disk are clean and not oily.

DISASSEMBLING AND ASSEMBLING PROCEDURE

- (1). Disassembling: please refer to exploded view drawing, start from right hand side, step by step according to the sequence.
- (2). Transmission and gear parts: please refer to exploded view drawing, start from left hand side,

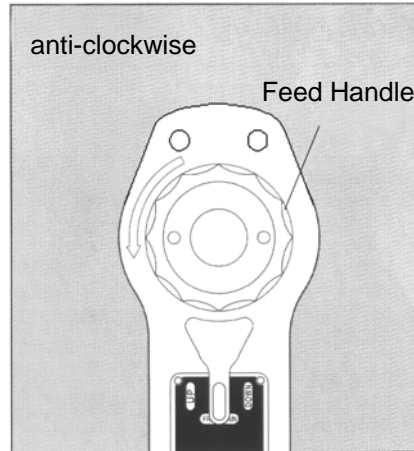

step by step according to the sequence.

- (3). Please spray the proper quantity of geese and the transmission shaft or axle should be lubricated properly.
- (4). When putting stopper on, you should check by turning direction indicator to the right then you will hear a click sound. It means stopper proper press the gear into feed ratchet. If you can not hear the click sound, move the stopper clockwise a little bit per drawing shown, then you will hear the click sound.

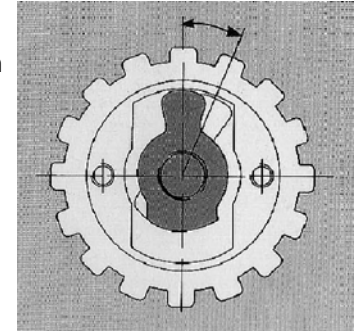

SPECIFICATIONS

specifications and dimensions are subject to change without notice.

Type		L-030	L-050
Rated capacity	(ton)	0.3	0.5
Lift height	(m)	1.0	1.5
Chain dia	(mm)	4.0	5.0
Net weight	(kg)	2.1	3.9
Min distance between hooks (G)	(mm)	235	275
Pull on lever to lift ful load	(kgf)	30	35
Dimensions (mm)	A	72	88
	B	23	26
	C	67	93
	G	235	275
	N	155	265
	F ₁	23	28

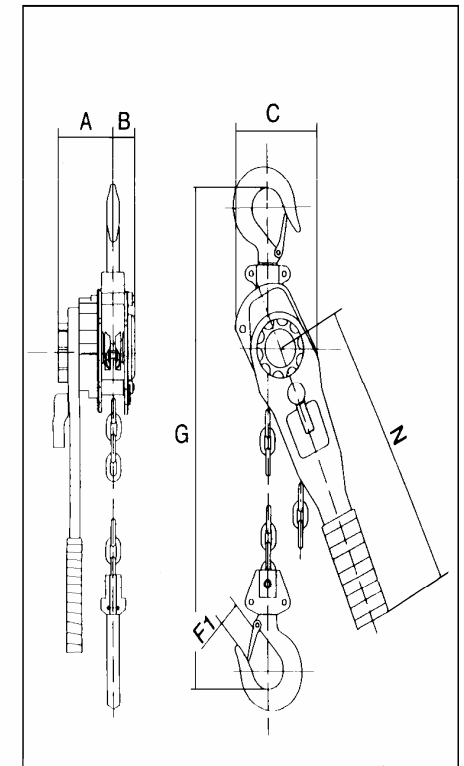

In addition to the standard lift, we offer up to 12m lift.